

## GENERAL TECHNICAL RIDER

### mnemonic nonstop

Martin Nachbar / Jochen Roller

Duration: approx. 70min, without break

Company: 3 Performers / 1 light technician / 1 sound technician  
1 Production Manager

Contact: Marek Lamprecht (stage)  
Fone: +49 - (0)179 - 213 90 25  
Email: [marek.lamprecht@web.de](mailto:marek.lamprecht@web.de)

Sofie Thyssen (light)  
Fone: +49-(0)172 - 230 50 89  
Email: [sofie.thyssen@hamburg.de](mailto:sofie.thyssen@hamburg.de)

Lars Müggenburg (sound)  
Fone: +49 - (0)179 - 451 56 45  
Email: [muegge66@qmx.de](mailto:muegge66@qmx.de)

DepArtment (tour management)  
Fone: +49 - (0)30 - 40 50 59 85  
Email: [info@dep-art-ment.com](mailto:info@dep-art-ment.com)

THIS IS A GENERAL TECHNICAL RIDER. IT HAS TO BE ADAPTED TO EACH THEATRE VENUE. PLEASE SEND US THE PLANS OF YOUR THEATRE IN DWG/DXF FORMAT OR IN PDF FORMAT.

The whole show (except the subtitles) will be operated from one performer upstage, exact position see plan. So, all mixers, consoles and boards (sound, light) have to be installed on stage. Ideally the technical desk (which is part of the set design) should look like this:



If possible we would appreciate to have all amplifiers and dimmers integrated in this place.

You can replace some of them with empty cases. Tables are not possible. The whole place should look like a real operating place. We do not bring any amplifiers or cases!

## **THE PRESENTER PROVIDES:**

### **SOUND:**

#### MIXER / STAGE:

- Mixer: 12 In / 4 Aux (Pre/Post switchable) / 4 Groups / par. EQ (preferred: Midas Venice160 or Soundcraft Delta DLX)

#### OUTBOARD EQUIPMENT

- 1 CD Player
- Reverb for vocals and guitar microphone (for example Lexicon PCM70 / TC M 2000)
- 2 Stereo graphic EQ

#### MICROPHONES:

- 3 Hand helds wireless (Shure or Sennheiser) with stands
- 1 wireless guitar sender (AKG or Sennheiser)
- 1 Shure SM57 with stand, for Guitar amplifier

#### PA (inclusive Amplification):

We need an adequate PA which fits for the venue with a subwoofer system.

(example: D&B E Series, Turbosound TQ 310)

- 4 Tops front (zero-line) (rigged)
- if necessary: 2 Tops delay-line (rigged)

#### 2 WAY MONITORING (INCLUSIVE AMPLIFICATION AND STEREO GRAPHIC EQ)

Four small but excellent monitors, two on each side lying on the floor (example: Nexo PS15, Turbosound TQ310)

### **VIDEO (only needed for subtitles of german text):**

(the subtitles will be operated from the usual FOH place in the tribune. We use Power Point on a Apple Macintosh laptop, which we bring)

- Beamer for subtitles on stage (rigged)
- VGA-Cable from FOH to the beamer

## LIGHTS

### LIGHTBOARD:

- Compulite Spark or Photon preferred (will be operated on stage)
- Programming: we need chaser (rate/intensity), cues with splitted (in-out) fade times, min. 10 submaster fader.

### LAMP UNITS:

- 04 Floodlights sym. 1kW (with Barndoors!!!)
- 16 PC 1,2kW
- 02 Profiles 1kW ca. 40°
- 01 Profile 1kW max. 20°
- 06 Striplights (Thomas Par16 Batten, D1621 or D1622) 1500W, 1,90m, used vertical on plates, or similar.

### COLOUR GELS:

- LEE 141 (8 sheets for PC)
- LEE 126 (1 sheets for PC)
- LEE 156 (2 sheets for PC)
- LEE 179 (6 sheets for PC)

### CHANNELS

- 24 Channels 2kW (Rig)
- 12 Channels 2kW (Floor)
- 03 Non-Dim-Channels for 3 HQL-Lamps (each 420W), and 2 Overhead-Projectors (Provided by the company). Please note that these circuits have to be controlled via the lightboard!

## STAGE:

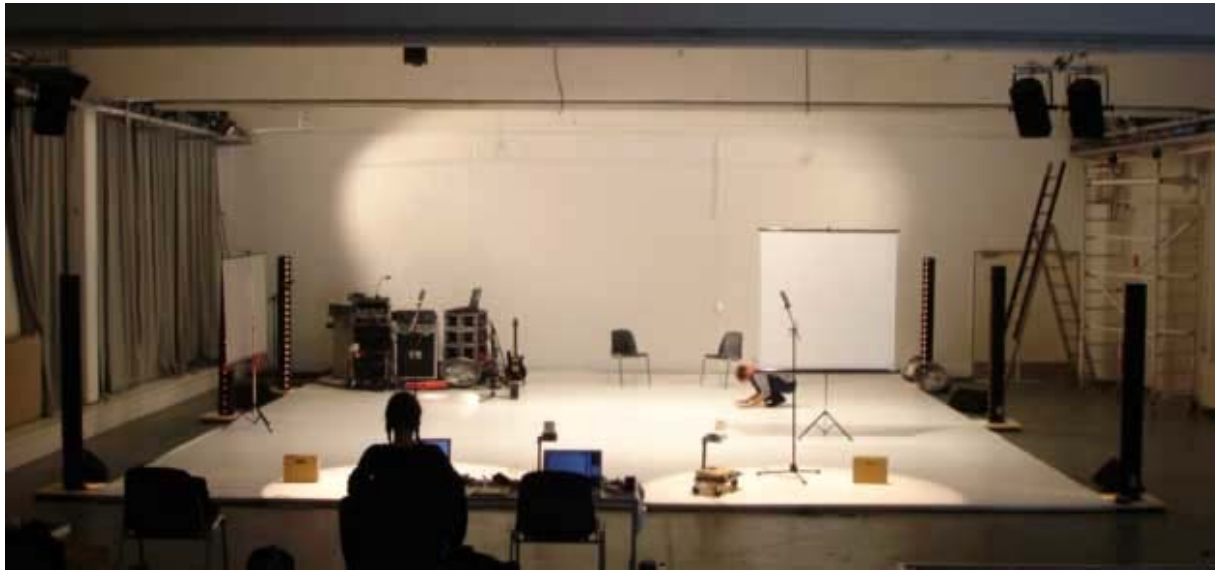

### Measures:

- Minimum Venue:           12,00m depth  
                                  11,00m wide  
                                  05,00m height
- Stage Measures / covered with white Marley:  
                                  10m depth  
                                  9m wide (better: 10m)

The backwall has to be white to project on it.  
If not we can use a white opera screen. Screen measures must be as wide as the white marley.

### FLOOR

- White Marley-Dancefloor (clean white!!) on the stage, width of 9m/10m. The Marley has to lie sideways.
- The white floor has to be placed on a wooden floor for dancing if the venue is not equipped with a wooden floor.

### CURTAINS

Open house: no curtains, legs, borders...

## MISCELLANEOUS

### PROPS

- Two chairs for performers on stage (if possible of the same type the audience sits on)

### EXHIBITION

- An exhibition in which parts of the working process are shown is an integral part of the performance. Ideally this exhibition is placed in the same room the performance takes place. A position in the foyer can also be well. Placing, hanging and lighting of the exhibition has to be talked over with the company. The audience must have the possibility to watch the exhibition before and after the performance.



**LOCAL CREW:**

FOR EXHIBITION

- 1 stage technician for setup / strike of exhibition

FOR ALL REHEARSALS AND PERFORMANCES

- 1 light technician Stand By
- 1 sound technician Stand By

SET UP / STRIKE

- 2 stage technicians for setup
- 2 light technicians
- 1 sound technician
- 1 video technician

**BACKSTAGE:**

WARDROBES

- 3 Places for performers (3 Gentlemen) with enlightened mirrors.
- Natural and carbonated Mineral water, coffee, tea, fruits, sweets

**THE COMPANY PROVIDES:**

- 2 Overhead projectors on rolling plates
- 2 Screens on stands for overhead projection (each ca.1,40m x 1,80m)
- 1 Screen 2,60m (wide) x 1,00m (height) to be hung near the centre of the stage for subtitles.
- 1 LED Display to be placed on the floor close to the tech desk
- 1 electric guitar
- 1 small guitar amplifier
- 3 HQL street lanterns to be placed on stage
- 3 big suitcases with exhibition material, costumes and props
- Laptop with subtitles in PowerPoint format

THIS TECHNICAL RIDER IS PART OF THE CONTRACT. CHANGES MUST BE TALKED OVER IN ADVANCE WITH THE RESPONSIBLES OF THE COMPANY.

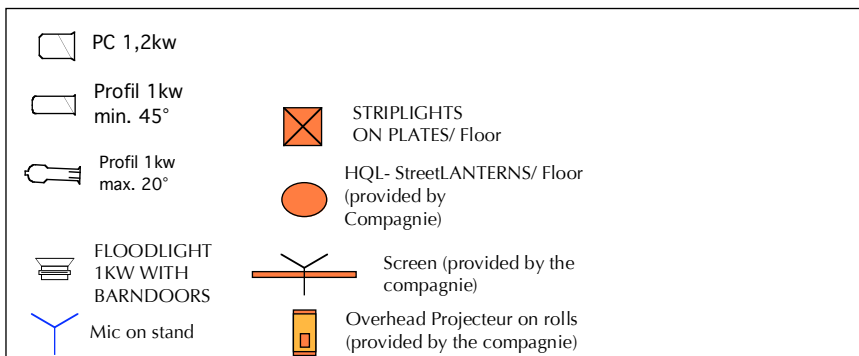
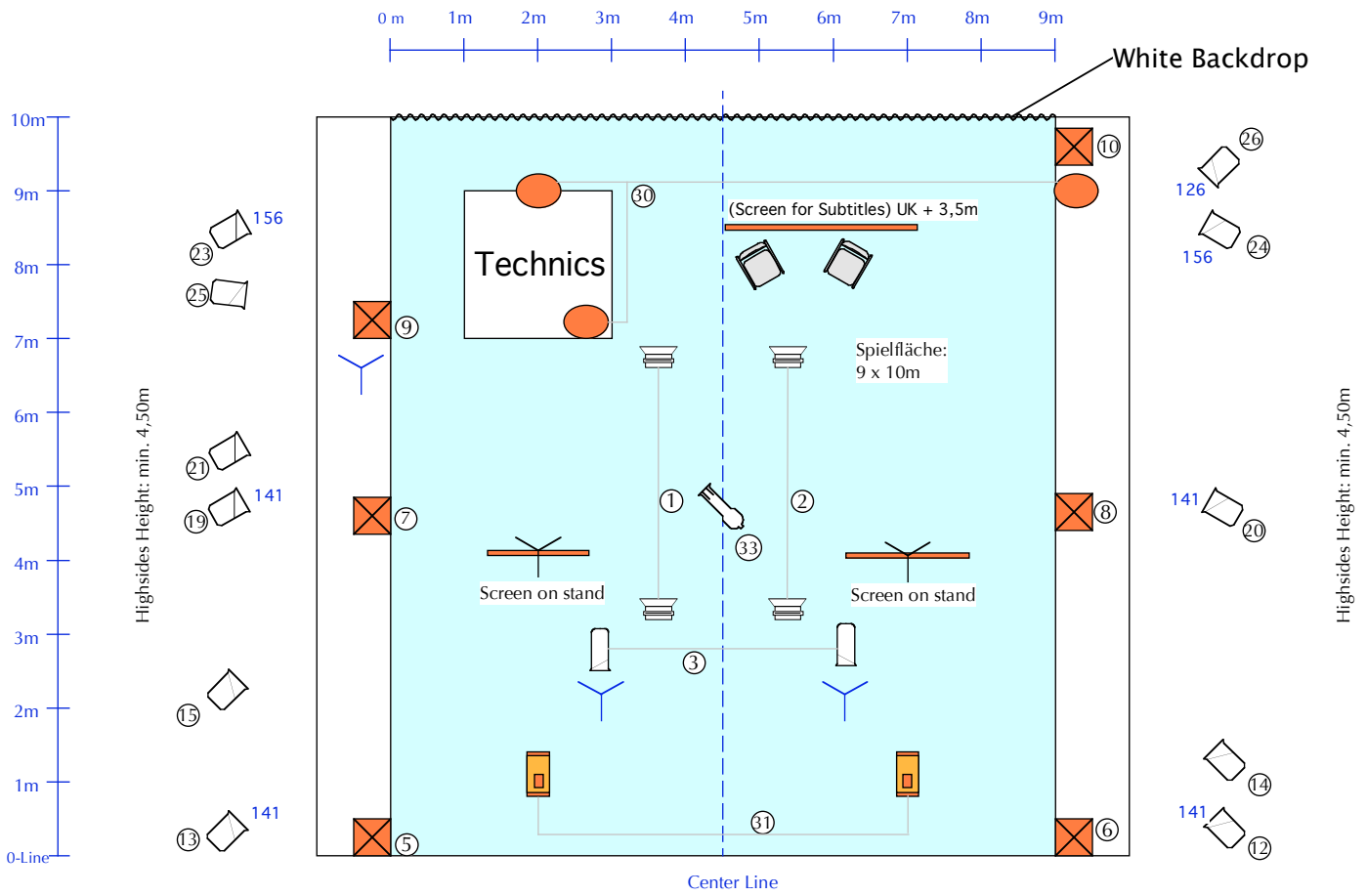

**"MNEMONIC NONSTOP"**

**Lights:** Sofie Thyssen / Marek Lamprecht  
+49 - 172 - 230 50 89  
sofie.thyssen@hamburg.de

**drawn by:** ST

**scale:** 1:100 (please check scale)

